

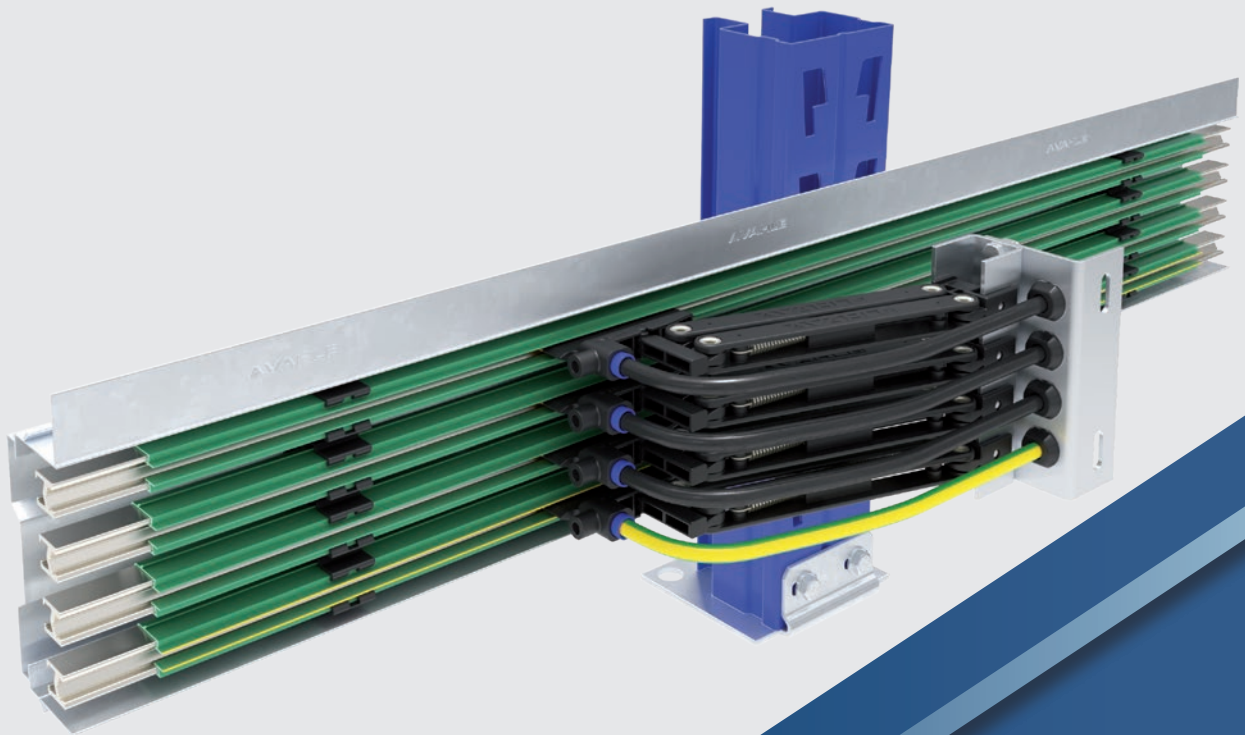

**MULTI SUPPORT PROFILE
VMT**





VAHLE MULTI SUPPORT PROFILE (VMT)

CONTENT

The VAHLE solution for automation	3	Feeding module MEU25-VMT.....	6
System layout	4	Joint splice BCB.....	6
Technical data	4	Potential equalization for VMT	7
VAHLE Multi Support Profile	5	Installation tools.....	7
Joint splice.....	5	Conductor systems for VMT.....	8
Suspension hangers	5	Compact current collectors	10

THE VAHLE SOLUTION FOR AUTOMATION

The VAHLE Multi Support Profile VMT has been specifically designed to meet highly diverse requirements of storage and retrieval installations and transfer cars. For other applications such as crane technology, please ask us. Parallel to that, it is possible to use VAHLE positioning systems. Another plus is the large support center distance which reduces component costs and facilitates quick installation.

SYSTEM SPECIFICATION

- Can be used with several VAHLE conductor systems
- Support center distance of up to 3.5 m (11'-6") possible
- Plug-in and clamping connection technology enables unprecedented fast installation
- Provides mechanical impact protection for conductor system
- Temperature fluctuations will not influence systems rigidity
- BG-compliant version of the Multi Support Profile
- Integration of all VAHLE positioning systems
- Attachment hangers for all commonly used rack upright profiles
- 4 to 7 poles; 60–400A with same profile
- Touch proof as per IP 23
- Electrically safe with potential equalization
- Simple and quick exchange of profile sections or subsections

POSSIBLE SYSTEM VARIANTS



U15



U25



VKS4 & 6

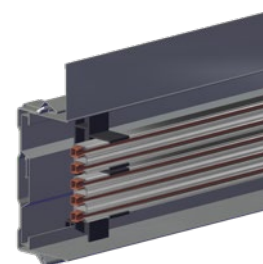

VCL4, 5 & 6

ACCESSORY COMPONENTS

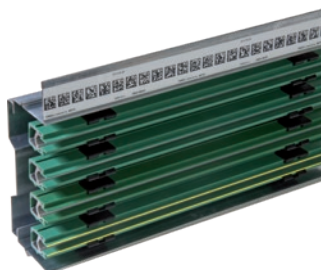

Data matrix tape



Bar code tape

SYSTEM LAYOUT

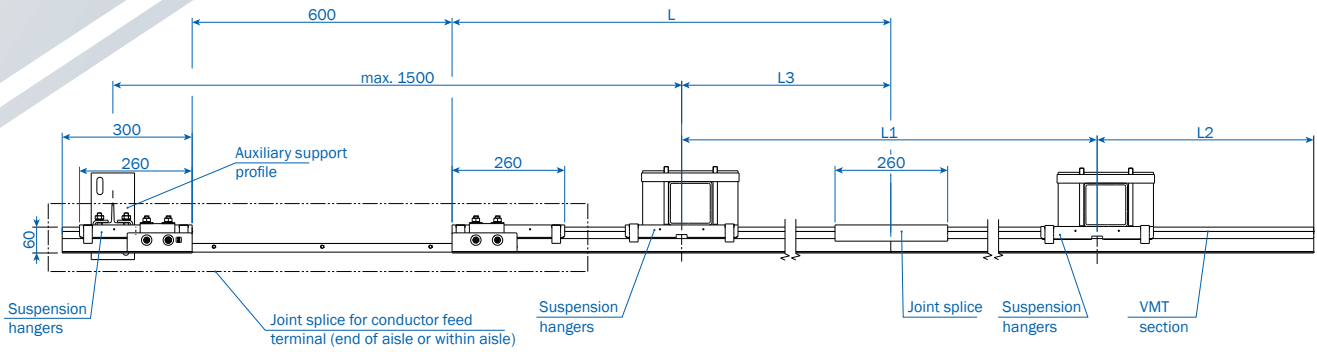

L = Length of VMT Multi Support Profile
 L1 = Support center distance max. 3.5 m

L2 = Overhang (max 0.5 m)
 L3 = Safety dimension for expansion min. 0.35 m

TECHNICAL DATA

- VMT Multi Support Profile..... Galvanized
- Grid dimension compact hanger..... 100 mm
- Profile length..... 6 m
- Support hanger Universal
- Max. support center distance 3.5 m (lateral arrangement)
 3 m (pendant arrangement)

SYSTEM DATA

- Number of poles..... 4-7
- Max. voltage 690 V
- Current..... 60-400 A
- Duty cycle..... 100 %
- Approvals UL
- Max. operating speed 600 m/min
- Temperature range -30 to +85 °C
- Application area Indoor system

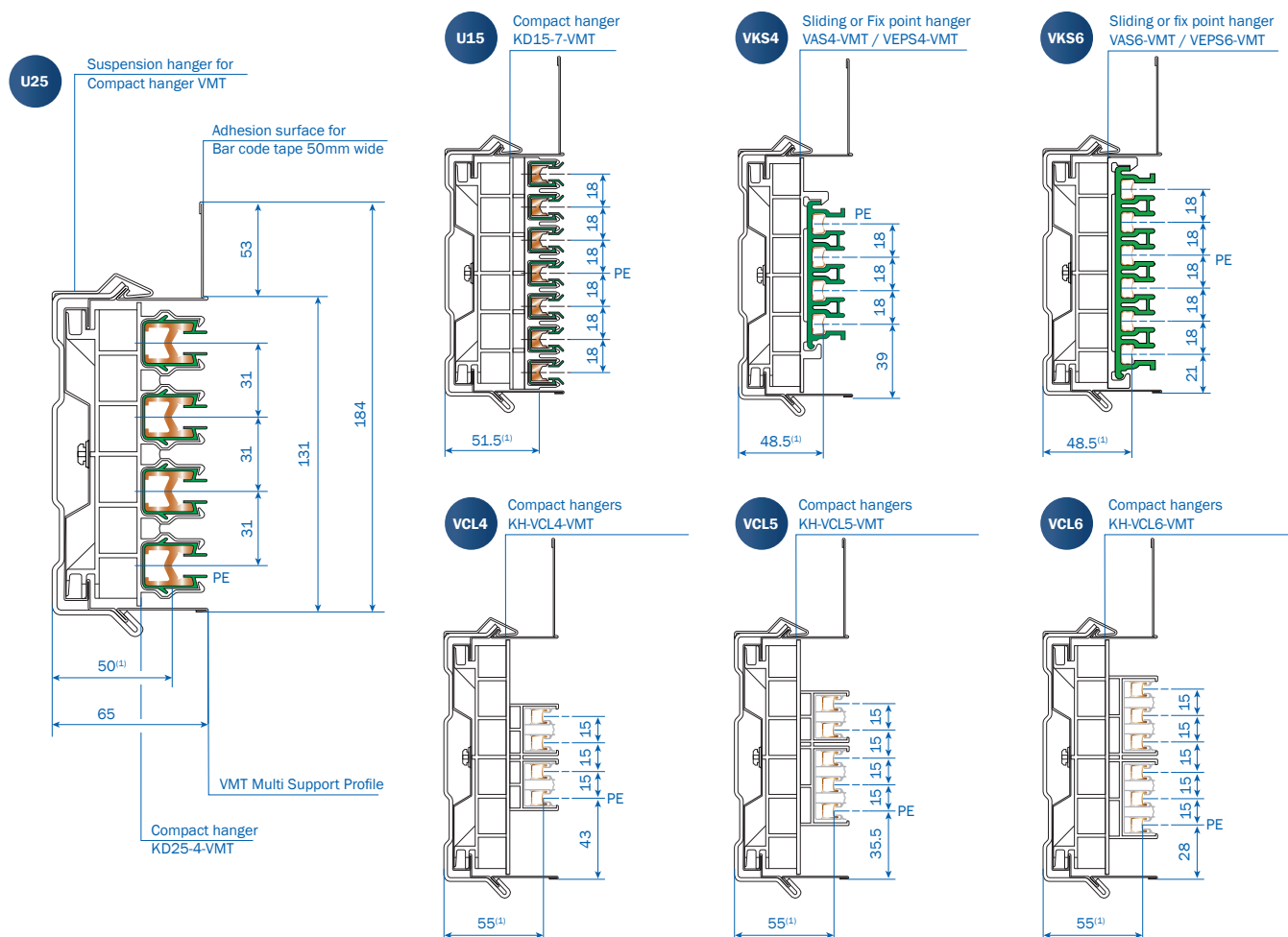

(1) Dimension support base to contact surface

VAHLE MULTI SUPPORT PROFILE

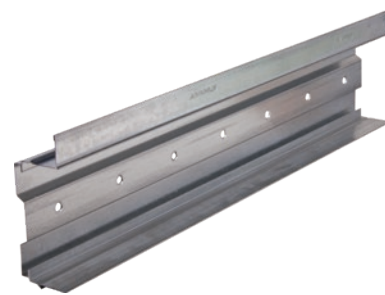

Type	Description	Weight kg	Order No.
VMT-6000	VAHLE Multi Support Profile 6 m long	12.336	171546

JOINT SPLICE



Type	Description	Weight kg	Order No.
KV-VMT	Clamping joint splice	0.845	171536

SUSPENSION HANGERS

SUSPENSION HANGERS WITH AUXILIARY SUPPORT

CLAMPING SUSPENSION HANGERS

BOLTED SUSPENSION HANGERS



AH-VMT-HS

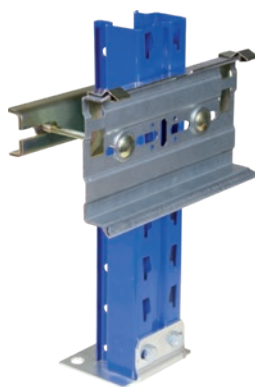

AH-VMT-SPW

AH-VMT 100-125⁽¹⁾

AH-VMT-BS



AH-VMT-S

Type	Weight kg	Clamping range mm	Order No.
AH-VMT-HS-500	2.783	-	171583
AH-VMT -SPW	0.985	max. 6 mm	171539
AH-VMT 100-115	1.603	100-115	171537
AH-VMT 110-125	1.615	110-125	171538
AH-VMT-BS	0.850	-	171540
AH-VMT-S	0.909	-	171547

(1) Additional clamping dimensions available per request

FEEDING MODULE MEU25-VMT

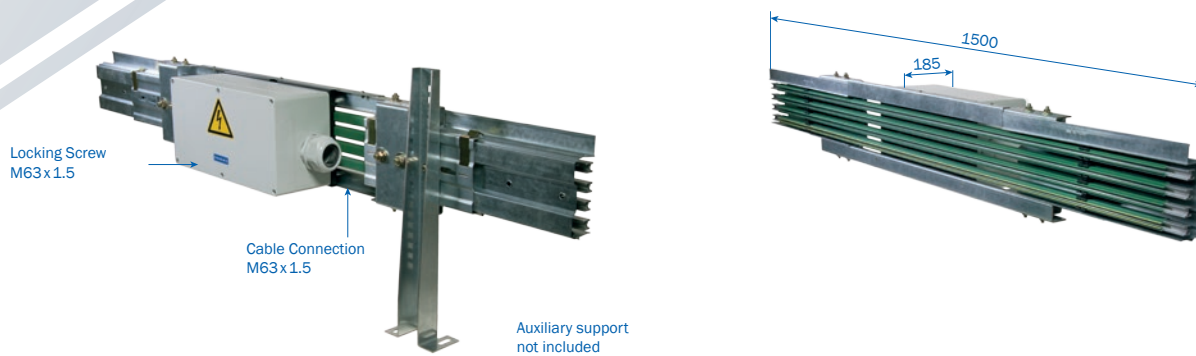

The power feed of the module MEU25, developed for the conductor system U25 in VAHLE Multi Support Profile, is an ex works completely pre-assembled unit including a pre-fitted terminal box with a cable gland M63 x 1.5 for 4-pole connecting cables with a maximum cable diameter of 45 mm (also both sided connection possible). Two versions allow the connecting of conductor systems made of copper or aluminum steel.

The mounting of the power feed can be carried out in the aisle or at the end of the aisle. The power feed module also serves as a fixed point of the bus bars.

Type	Description	Weight kg	Order No.
MEU25/125AE-VMT	Feeding module U25AE 320 A	20.205	171585
MEU25/125C-VMT	Feeding module U25C 450 A	25.000	171584

JOINT SPLICE BCB

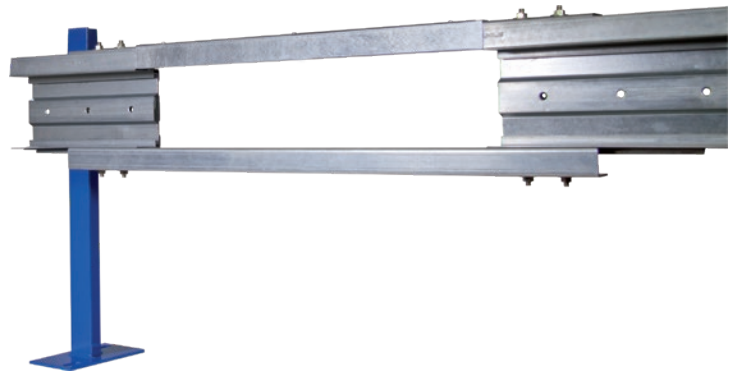

Type	Description	Weight kg	Order No.
VMTB900-ESST	Connection within aisle	10.517	171548
VMTB900-ESAE	Connection at end of aisle	11.120	171549

POTENTIAL EQUALIZATION FOR VMT

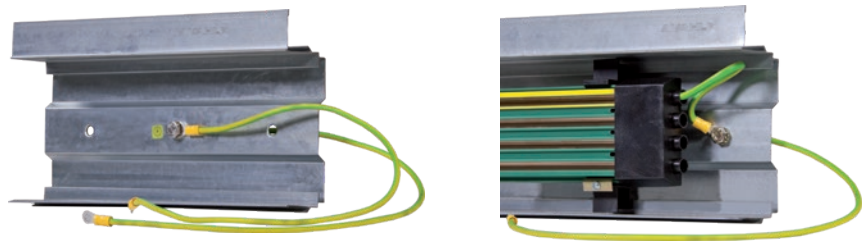

Type	Description	Weight kg	Order No.
VSPA-VMT-600	Connection set U15 U25	0.300	171563
VSPA-VMT-200-VKS4-R	Connection set VKS4 (right side)	0.443	171564
VSPA-VMT-200-VKS4-L	Connection set VKS4 (left side)	0.443	171566
VSPA-VMT-200-VKS5+6-R	Connection set VKS5 VKS6 (right side)	0.457	171565
VSPA-VMT-200-VKS5+6-L	Connection set VKS5 VKS6 (left side)	0.457	171567
VSPA-VMT-600-VCL	Connection set VCL	0,300	171817

INSTALLATION TOOLS



Cutting guide

Installation pliers

Type	Description	Weight kg	Order No.
SVU-VMT	Cutting guide for sub-sections	2.570	171561
MZ-VMT	Installation pliers for joint splices	0.700	171533

VAHLE CONDUCTOR SYSTEMS FOR VMT

INSULATED CONDUCTORS U15C

Type	Description	Weight kg	Order No.
U15/25C-6000PH-BA	6m section phase	1.800	162136
U15/25C-6000PE-AA	6m section PE	1.800	162196
VM-UV15-K4	Joint splice	0.040	160102
ES-UE15-K4	Feed terminal	0.040	160107
ES-UEG15-K4	Feed terminal	0.060	160216
KD15-7-VMT	Compact hanger	0.048	171524
FP-USK15-K4	Locating clamp	0.030	160106
EK-UK15-L	End cap	0.010	160109

INSULATED CONDUCTORS U25C

Type	Description	Weight kg	Order No.
U25/100C-6000PH-BA	6m section phase	6.110	171046
U25/100C-6000PE-AA	6m section PE	6.110	171146
VM-UV25	Joint splice	0.190	170595
KD25-4-VMT	Compact hanger	0.044	171523
FP-USK25-K4	Locating clamp	0.026	170010
ES-UE25-L-B	Feed terminal	0.190	170599
ES-UEG25-L-B	Feed terminal	0.560	170597
EK-UK25-L	End cap	0.005	170013

INSULATED CONDUCTORS U25AE

Type	Description	Weight kg	Order No.
U25/90AE-6000PH-BA	6m section phase 90 mm ² cross section	2.630	171246
U25/90AE-6000PE-AA	6m section PE 90 mm ² cross section	2.630	171256
U25/125AE-6000PH-BA	6m section phase 125 mm ² cross section	3.290	171286
U25/125AE-6000PE-AA	6m section PE 125 mm ² cross section	3.290	171296
VM-UV25AE-B	Joint splice	0.150	170960
KD25-4-VMT	Compact hanger	0.044	171523
FP-USK25-K4	Locating clamp	0.026	170010
ES-UE25AE-L-B	Feed terminal	0.150	171158
ES-UEG25AE-L-B	Feed terminal	0.460	170962
EK-UK25-L	End cap	0.005	170013

VAHLE CONDUCTOR SYSTEMS FOR VMT

ENCLOSED COMPACT CONDUCTORS VKS4

Type	Description	Weight kg	Order No.
VKS4/60-6000HSA	6 m section HS 60 A	8.880	153996
VKS4/100-6000HSA	6 m section HS 100 A	10.248	154006
VKS4/120-6000HSA	6 m section HS 120 A	11.094	154016
VKS4/140-6000HSA	6 m section HS 140 A	11.904	154316
VM-SVN4/10-100	Joint splice material up to 100 A	0.142	156535
VM-SVN4/120-140	Joint splice material up to 120 A	0.136	156536
ES-VNS4/60-140	Line feed with terminal box	1.984	157146
ES-VLS4/60	Line feed with single cables 10-60 A	0.061	156947
ES-VLS4/100-120	Line feed with single cables 100-120 A	0.179	156943
ES-VLS4/140	Line feed with single cables 140 A	0.239	156957
VAS4-VMT	Sliding hangers	0.036	171526
VEPS4-VMT	Fix point hangers	0.042	171527
EK-VES4-L	End cap, lose	0.040	150140
VEKS4/10-120L	End feed 10-120 A	1.230	156421

ENCLOSED COMPACT CONDUCTORS VKS5

Type	Description	Weight kg	Order No.
VKS5/60-6000HSA	6 m section HS 60 A	12.348	154096
VKS5/100-6000HSA	6 m section HS 100 A	13.752	154106
VKS5/120-6000HSA	6 m section HS 120 A	14.628	154116
VKS5/140-6000HSA	6 m section HS 140 A	15.438	154876
VM-SVN5/10-100	Joint splice material up to 100 A	0.180	156537
VM-SVN5/120-140	Joint splice material up to 120 A	0.188	156538
ES-VNS5/60-140	Line feed with terminal box	2.133	157145
ES-VLS5/60	Line feed with single cables 10-60 A	0.145	156946
ES-VLS5/100-120	Line feed with single cables 100-120 A	0.119	156942
ES-VLS5/140	Line feed with single cables 140 A	0.129	156956
VAS6-VMT	Sliding hangers	0.036	171525
VEPS6-VMT	Fix point hangers	0.042	171528
EK-VES6-L	End cap, loose	0.050	152140
VEKS5/10-120L	End feed 10-120 A	1.380	156420

VAHLE CONDUCTOR SYSTEMS FOR VMT

ENCLOSED COMPACT CONDUCTORS VKS6

Type	Description	Weight kg	Order No.
VKS6/60-6000HSA	6m section PH 60 A	13.278	154196
VKS6/100-6000HSA	6m section PH 100 A	14.616	154206
VKS6/120-6000HSA	6m section PH 120 A	15.460	154216
VKS6/140-6000HSA	6m section PH 140 A	16.158	152606
VM-SVN6/10-100	Joint splice material up to 100 A	0.194	156539
VM-SVN6/120-140	Joint splice material up to 120 A	0.194	156540
ES-VNS6/60-140	Line feed with terminal box	2.266	157144
ES-VLS6/60	Line feed with single cables 10-60 A	0.123	156945
ES-VLS6/100-120	Line feed with single cables 100-120 A	0.255	156941
ES-VLS6/140	Line feed with single cables 140 A	0.359	156955
VAS6-VMT	Sliding hangers	0.036	171525
VEPS6-VMT	Fix point hangers	0.042	171528
EK-VES6-L	End cap, loose	0.050	152140
VEKS6/10-120L	End feed 10-120 A	1.460	156419

COMPACT CONDUCTOR SYSTEM VCL4 (CU)

Type	Description	Weight kg	Order No.
VCL2/100C-4000HSC	4 m section PE 100 A	2.406	281534
VCL2/100C-4000SSD	4 m section PH 100 A	2.406	281524
VM-VCL2-7	Joint splice material up to 100 A	0.024	281559
ESM-VCL2-100-HSC-R	End segment right	0.324	281515
ESM-VCL2-100-HSC-L	End segment left	0.324	281518
ESM-VCL2-100-SSD	End segment	0.324	281510
US-VCL2-7-F	Transition piece with fixed point	0.055	281556
US-VCL2-7	Transition piece without fixed point	0.052	281555
Adapter-US-VCL4-5-6-F-VMT-K	Fix point adapter		171821
ES-VCL2-100C-100A-HSC	Line feed up to 100 A	0.640	281623
ES-VCL2-100C-100A-SSD	Line feed up to 100 A	0.640	281622
DT-DVCL2/100C-HSC ⁽¹⁾	Expansion section	0.324	281507
DT-DVCL2/100C-SSD ⁽¹⁾	Expansion section	0.324	281506
KH-VCL4-VMT	Sliding hanger	0.385	171818

(1) max. current 50 A, use of a second feeder at 100 A necessary.
System lengths up to 150 m can be installed without additional expansion compensation.

COMPACT CONDUCTOR SYSTEM VCL5 (CU)

Type	Description	Weight kg	Order No.
VCL3/100C-4000HSC	4 m section PE 100 A	3.522	281594
VCL2/100C-4000SSD	4 m section PH 100 A	2.406	281524
VM-VCL3-7	Joint splice material up to 100 A	0.034	281577
VM-VCL2-7	Joint splice material up to 100 A	0.024	281559
ESM-VCL3-100-HSC-R	End segment right	0.662	281579
ESM-VCL3-100-HSC-L	End segment left	0.622	281580
ESM-VCL2-100-SSD	End segment	0.324	281510
US-VCL3-7-F	Transition piece with fixed point	0.079	281588
US-VCL3-7	Transition piece without fixed point	0.076	281589
US-VCL2-7-F	Transition piece with fixed point	0.049	281554
US-VCL2-7	Transition piece without fixed point	0.046	281553
Adapter-US-VCL4-5-6-F-VMT-K	Fix point adapter		171821
ES-VCL3-100C-100A-HSC	Line feed up to 100 A	0.959	281621
ES-VCL2-100C-100A-SSD	Line feed up to 100 A	0.640	281622
DT-DVCL3/100C-HSC ⁽¹⁾	Expansion section	0.953	281600
DT-DVCL2/100C-SSD ⁽¹⁾	Expansion section	0.324	281506
KH-VCL5-VMT	Sliding hanger	0.397	171819

COMPACT CONDUCTOR SYSTEM VCL6 (CU)

Type	Description	Weight kg	Order No.
VCL3/100C-4000HSC	4 m section PE 100 A	3.522	281594
VCL3/100C-4000SSD	4 m section PH 100 A	3.522	281584
VM-VCL3-7	Joint splice material up to 100 A	0.034	281577
ESM-VCL3-100-HSC-R	End segment right	0.662	281579
ESM-VCL3-100-HSC-L	End segment left	0.622	281580
ESM-VCL3-100-SSD	End segment	0.622	281578
US-VCL3-7-F	Transition piece with fixed point	0.079	281588
US-VCL3-7	Transition piece without fixed point	0.076	281589
Adapter-US-VCL4-5-6-F-VMT-K	Fix point adapter		171821
ES-VCL3-100C-100A-HSC	Line feed up to 100 A	0.959	281621
ES-VCL3-100C-100A-SSD	Line feed up to 100 A	0.959	281620
DT-DVCL3/100C-HSC ⁽¹⁾	Expansion section	0.953	281600
DT-DVCL3/100C-SSD ⁽¹⁾	Expansion section	0.953	281599
KH-VCL6-VMT	Sliding hanger	0.403	171820

(1) max. current 50 A, use of a second feeder at 100 A necessary.
System lengths up to 150 m can be installed without additional expansion compensation.

CONDUCTOR LINE COMPONENTS FOR VMT

COMPACT CONDUCTOR SYSTEM VCL4 (FE) ⁽²⁾

Type	Description	Weight kg	Order No.
VCL2/40F-4000HSC	4 m section PE 40 A	2.190	281554
VCL2/40F-4000SSD	4 m section PH 40 A	2.190	281544
VM-VCL2-7	Joint splice material up to 100 A	0.024	281559
ESM-VCL2-40F-HSC-R	End segment right	0.297	281517
ESM-VCL2-40F-HSC-L	End segment left	0.297	281519
ESM-VCL2-40F-SSD	End segment	0.297	281516
US-VCL2-7-F	Transition piece with fixed point	0.055	281556
US-VCL2-7	Transition piece without fixed point	0.052	281555
Adapter-US-VCL4-5-6-F-VMT-K	Fix point adapter		171821
ES-VCL2-40F-HSC	Line feed up to 50 A	0.297	281505
ES-VCL2-40F-SSD	Line feed up to 50 A	0.297	281504
DT-DVCL2/40F-HSC ⁽¹⁾	Expansion section	0.297	281509
DT-DVCL2/40F-SSD ⁽¹⁾	Expansion section	0.297	281508
KH-VCL4-VMT	Sliding hanger	0.385	171818

COMPACT CONDUCTOR SYSTEM VCL6 (FE) ⁽²⁾

Type	Description	Weight kg	Order No.
VCL3/40F-4000HSC	4 m section PE 40 A	3.300	281614
VCL2/40F-4000SSD	4 m section PH 40 A	2.190	281544
VM-VCL3-7	Joint splice material up to 100 A	0.034	281577
VM-VCL2-7	Joint splice material up to 100 A	0.024	281559
ESM-VCL3-40F-HSC-R	End segment right	0.625	281586
ESM-VCL3-40F-HSC-L	End segment left	0.625	281587
ESM-VCL2-40F-SSD	End segment	0.297	281516
US-VCL3-7-F	Transition piece with fixed point	0.079	281588
US-VCL3-7	Transition piece without fixed point	0.076	281589
US-VCL2-7-F	Transition piece with fixed point	0.055	281556
US-VCL2-7	Transition piece without fixed point	0.052	281555
Adapter-US-VCL4-5-6-F-VMT-K	Fix point adapter		171821
ES-VCL3-40F-HSC	Line feed up to 50 A	0.892	281598
ES-VCL2-40F-SSD	Line feed up to 50 A	0.297	281504
DT-DVCL3/40F-HSC ⁽¹⁾	Expansion section	0.898	281606
DT-DVCL2/40F-SSD ⁽¹⁾	Expansion section	0.297	281508
KH-VCL5-VMT	Sliding hanger	0.397	171819

(1) max. current 50 A. System lengths up to 150 m can be installed without additional expansion compensation.

(2) max. amperage 40 A.

COMPACT CONDUCTOR SYSTEM VCL6 (FE) ⁽²⁾

Type	Description	Weight kg	Order No.
VCL3/40F-4000HSC	4 m section PE 40 A	3.300	281614
VCL3/40F-4000SSD	4 m section PH 40 A	3.300	281604
VM-VCL3-7	Joint splice material up to 100A	0.034	281577
ESM-VCL3-40F-HSC-R	End segment right	0.625	281586
ESM-VCL3-40F-HSC-L	End segment left	0.625	281587
ESM-VCL3-40F-SSD	End segment	0.625	281585
US-VCL3-7-F	Transition piece with fixed point	0.079	281588
US-VCL3-7	Transition piece without fixed point	0.076	281589
Adapter-US-VCL4-5-6-F-VMT-K	Fix point adapter		171821
ES-VCL3-40F-HSC	Line feed up to 50A	0.892	281598
ES-VCL3-40F-SSD	Line feed up to 50A	0.892	281597
DT-DVCL3/40F-HSC ⁽¹⁾	Expansion section	0.898	281606
DT-DVCL3/40F-SSD ⁽¹⁾	Expansion section	0.898	281605
KH-VCL6-VMT	Sliding hanger	0.403	171820

(1) max. current 50A. System lengths up to 150 m can be installed without additional expansion compensation.

(2) max. amperage 40A.

COMPACT CURRENT COLLECTORS

COMPACT CURRENT COLLECTOR SA-KEH 100 FOR U25

Contact pressure: approx. 12 N per brush
 Number of poles: 4
 Connecting cable: 16 mm², 2 m long
 Max. current: 100 A
 Stroke: ±30 mm
 Swivel: ±20 mm

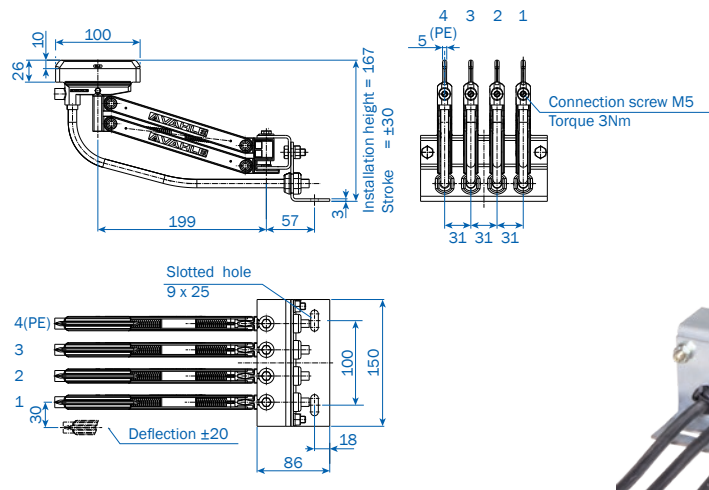

Type	Weight kg	Number of poles	Base plate	Order No.
SA-KEH100-4-31HSAD-2,0-04-04	3.100	4	PE on No. 4	171529/00-D2
SA-KEH100-4-31HSAD-2,0-01-04	3.100	4	PE on No. 1	171530/00-A2

COLLECTOR BRUSHES

Type	Weight kg	Thickness of brush mm	RH mm	for collector	Order No.
SK-KMK100/KEH-04	0.077	4	1.50	KEH 100	10000053

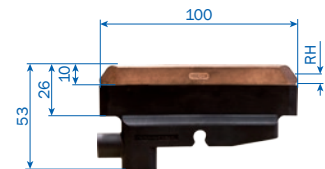

COMPACT CURRENT COLLECTORS SA-KESR FOR U15 AND VKS

Contact pressure: approx. 7 N per brush
 Number of poles: 4-7
 Connecting cable: 2.5-10 mm²
 Max. current: 32-63 A
 Deflection: ±15 mm



Standard

with adapter

with adapter and cable terminals

COMPACT CURRENT COLLECTORS SA-KESL FOR U15 AND VKS

Contact pressure: approx. 7 N per brush
 Number of poles: 4-7
 Connecting cable: 2.5-10 mm²
 Max. current: 32-63 A
 Deflection: ±30 mm

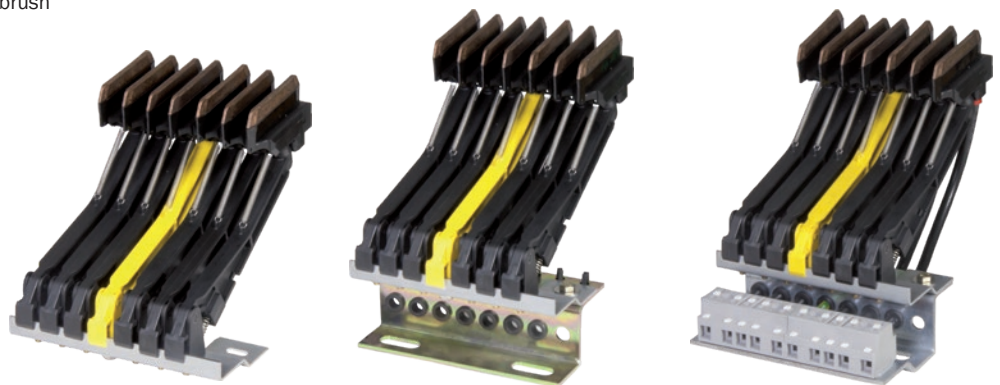

Standard

with adapter

with adapter and cable terminals

COMPACT CURRENT COLLECTORS SA-PASK FOR VCL

Contact pressure: approx. 4 N per brush
 Number of poles: 4-6
 Connecting cable: 2.5-6 mm²
 Max. current: 50 A
 Deflection: ±20 mm
 Hub: ±15 mm

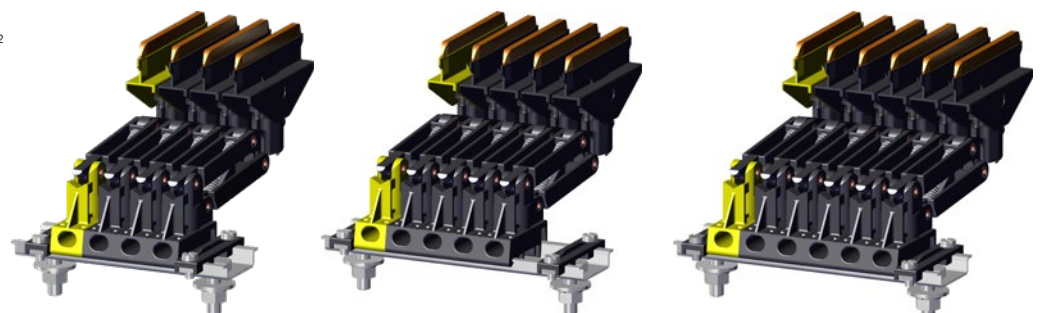

for VCL4

for VCL5

for VCL6



Paul Vahle GmbH & Co. KG

Westicker Str. 52
59174 Kamen
Germany

Phone: +49 2307 704-0

Fax: +49 2307 704-444

info@vahle.de

www.vahle.com