



vCOM – COMMUNICATION SYSTEMS
SMGM | SMGX



SMGM | SMGX – KEY HIGHLIGHTS

WIDE RANGE OF APPLICATIONS

With the vCOM product family for mobile data transmission, VAHLE serves indoor installations with the SMGM as well as outdoor installations with the SMGX. This product variety offers a selection for different segment lengths and mechanical tolerances.

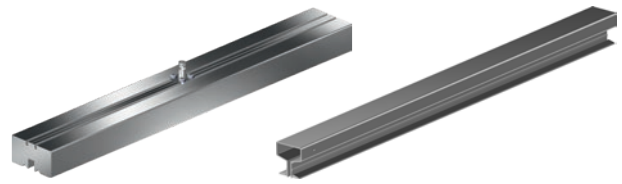

HF-SECURE

The SMG profile's interference-free design prevents signals from transmitting beyond the aluminum housing, allowing it to work alongside other industrial free radio systems. A radio license is not required. All HF components are factory tested and measured before each delivery, ensuring steady HF behavior.

STEADY SIGNAL QUALITY

Low-wear skids and a pressure spring provide a stable mechanical guide and steady immersion depth of the data coupler into the SMG profile, guaranteeing secure signals and data transmission quality even in curved stretches.

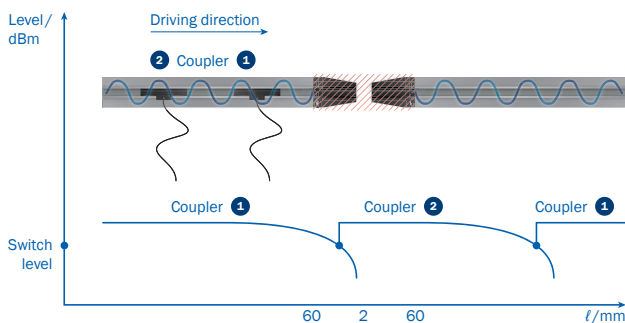
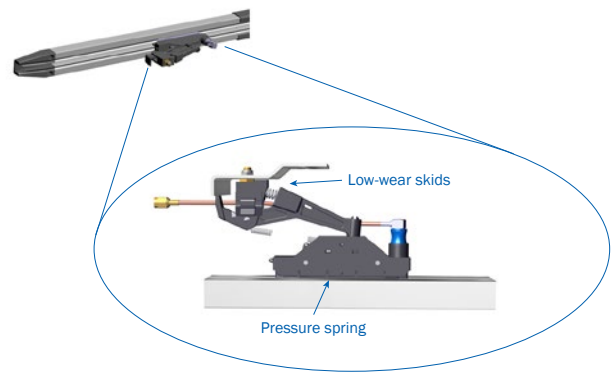

RELIABLE DATA TRANSMISSION

Connected data couplers ease segment transitions allowing for interruption-free data transmission. VAHLE's SMGM technology is suitable for use in people-safe applications.

TRANSPARENT SYSTEM

Data transmission through SMGM occurs wirelessly within the SMG profile and no changes to the data occur during the transfer (packet-oriented). The SMGM interface does not require IP addresses.

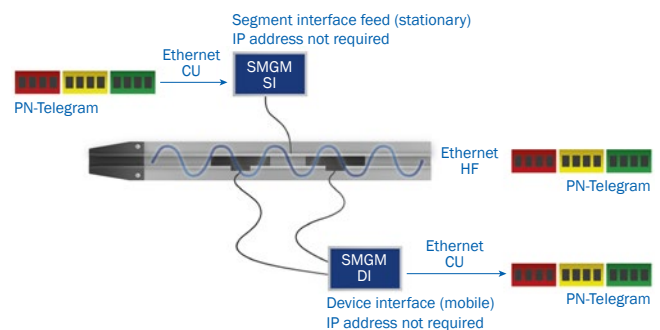

SMGM | SMGX – OPERATION

Modern production requires expansive volumes of data transmission for diagnosis and management. While this data is often transmitted for simple transport tasks in mobile applications via conductor lines with low transmission rates, this method of communication cannot stand up to the requirements of more complex applications that demand higher data rates. The data communication system SMGM (Slotted Microwave Guide Mini) was especially developed for these applications and enables the integration of fail-safe data transmission into proven VAHLE conductor systems. The SMGM system is especially recommended for indoor applications, for example for EMS, skilnet and shuttle systems.

The SMGX system was developed on the basis of the SMGM system and is based on the same functional principle. The main difference lies in the mechanical components of the data rail and the matching mobile coupler. For robust and outdoor applications, for example crane systems and amusement rides, the SMGX "Slotted Microwaves Guide Extreme" is recommended.

FUNCTIONAL PRINCIPLE

The data transmission between the stationary management and the users on the mobile side occurs as locally restricted high frequency communication via slotted hollow conductor. The transmission path is divided into separately fed segments due to the attenuation properties of the slotted hollow conductor mechanics. The maximum length of a segment is defined by the amount of users per segment and the used cable lengths. This is determined in the level calculation.

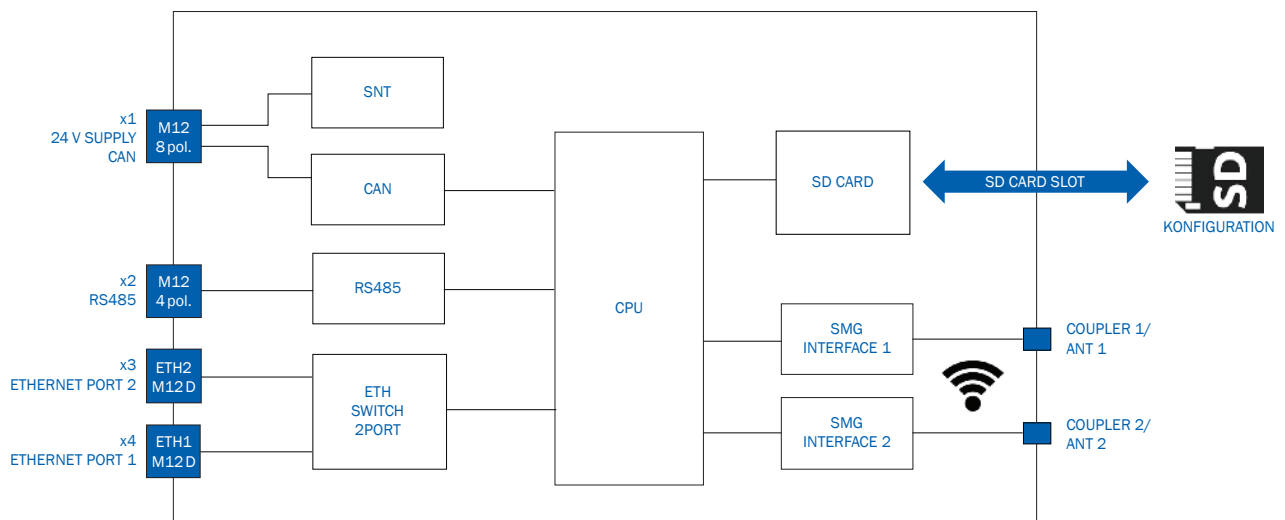

The vCOM interface has an Ethernet-based interface for connecting to the management (stationary side) and/or to the subordinate IO devices (mobile side). The SMGM and SMGX are optimized for both PROFINET-IO and PROFIsafe transmission.

SMGM – SYSTEM OVERVIEW

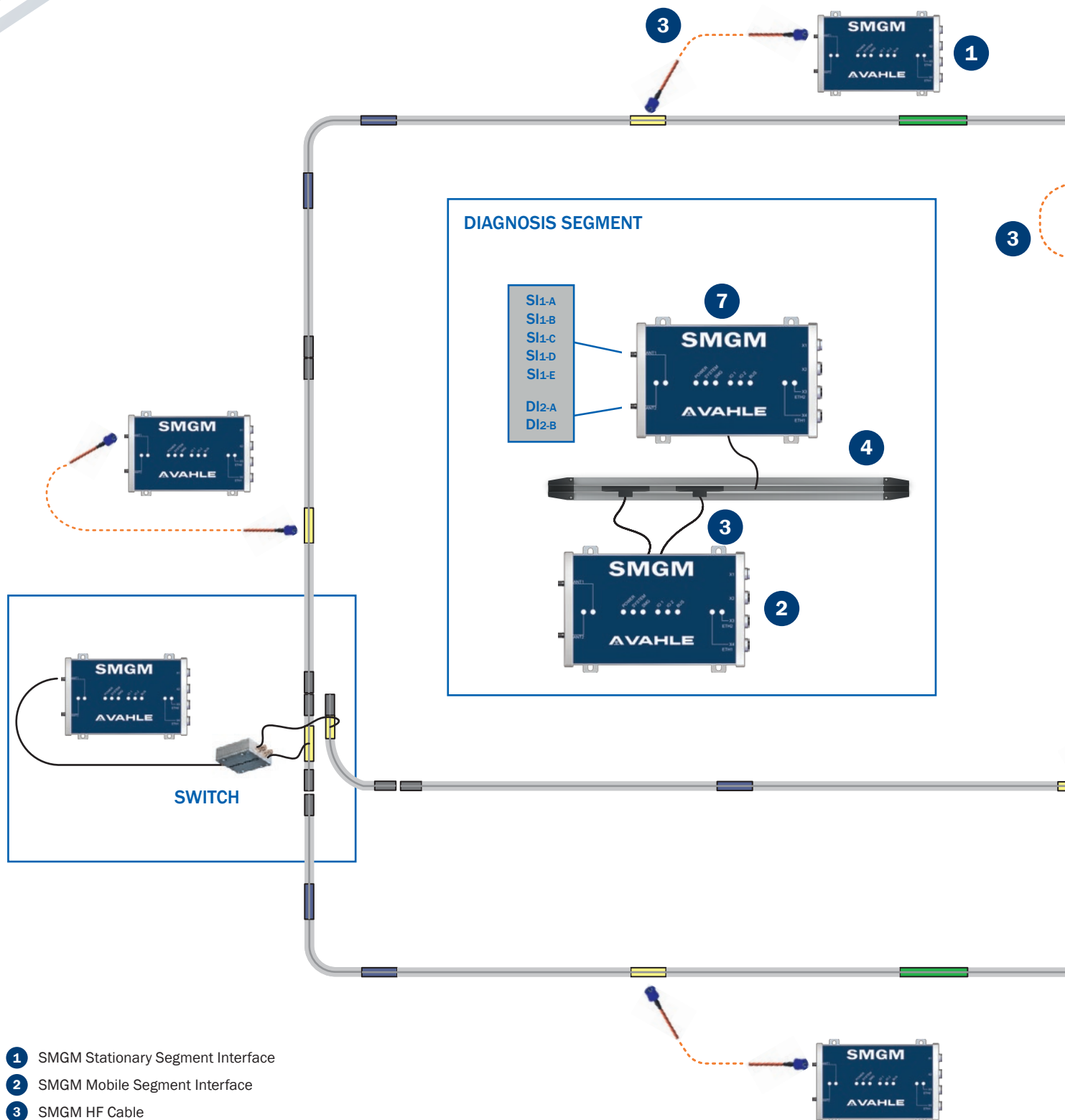

- ① SMGM Stationary Segment Interface
- ② SMGM Mobile Segment Interface
- ③ SMGM HF Cable
- ④ SMGM Profile
- ⑤ SMGM Track Change
- ⑥ SMGM Mobile Coupler
- ⑦ SMGM System Controller

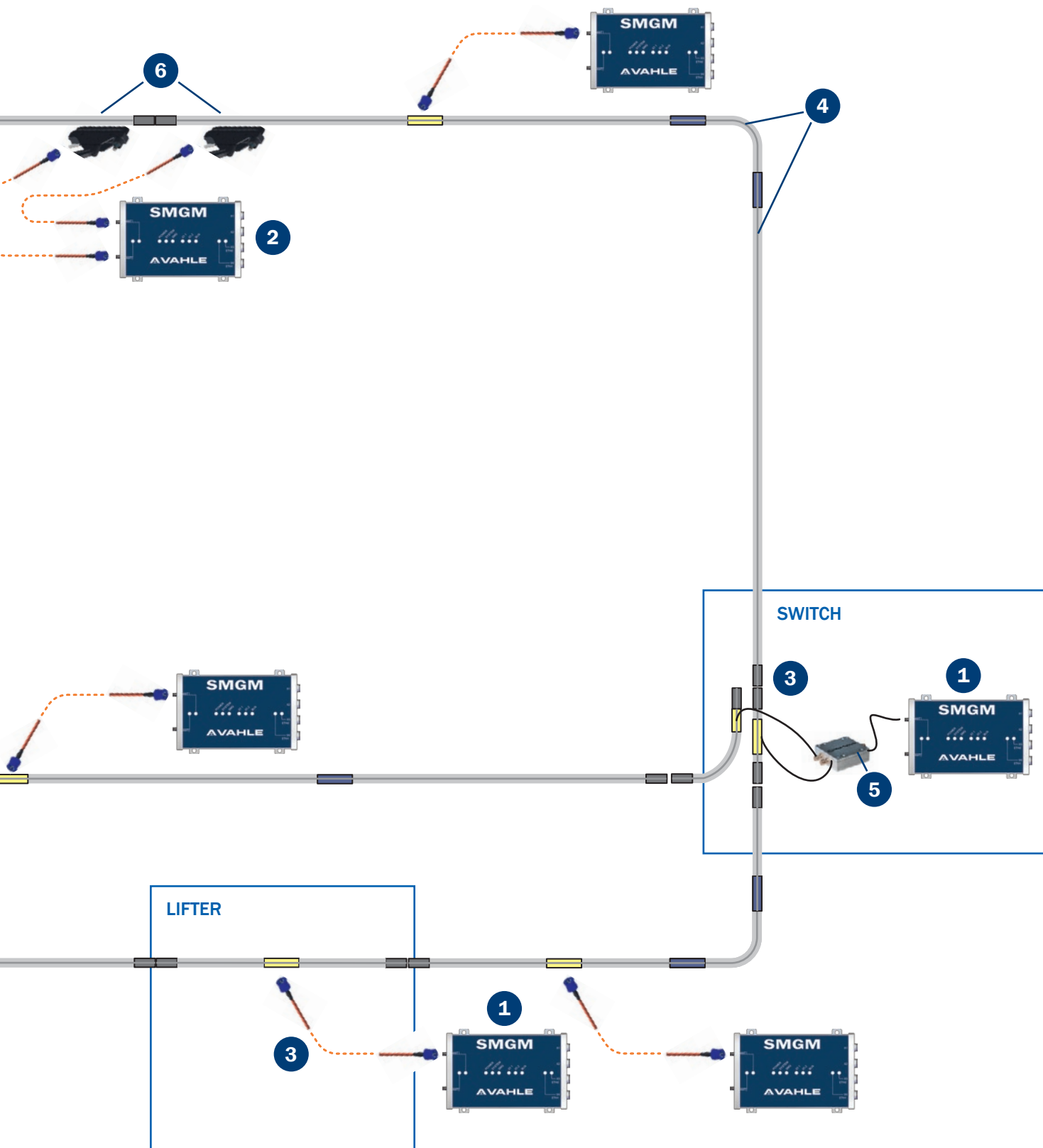

SMGM – DIAGNOSIS / SERVICE

COMPONENT AND SYSTEM QUALITY SURVEILLANCE

All SMGM components are under surveillance via the system controller regarding their availability. If one of the components becomes inoperative, a respective prompt will be sent to the superordinate management component/controller.

For safe operation, compliance with different communication parameters (e.g. levels) is necessary. The stationary interface permanently monitors the compliance of these system-relevant parameters. If one of these parameters is not met, the system controllers receives an error message via Ethernet which is then forwarded to the superordinate management component/controller.

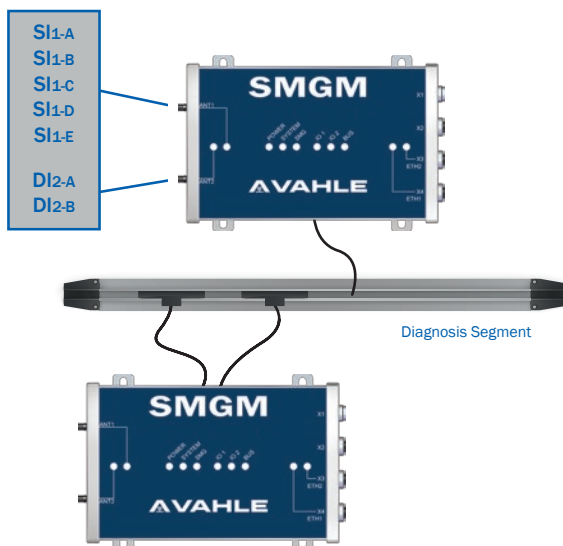

DIAGNOSIS SEGMENT

The diagnosis segment provides the opportunity of HF related diagnosis (communication/reception quality) of mobile SMGM interfaces and the associated data couplers. A mechanically and electrically separate SMG rail segment must be defined for this process.

SERVICE – REPLACEMENT CONCEPT

All parameters relevant for operation are saved on the SD card of the SMG interface. During replacement, simply insert the SD card of the defective module into the SD card slot of the universally usable replacement unit (SMG-RU). Module type and configuration are adopted via the SD card, without separate programming.

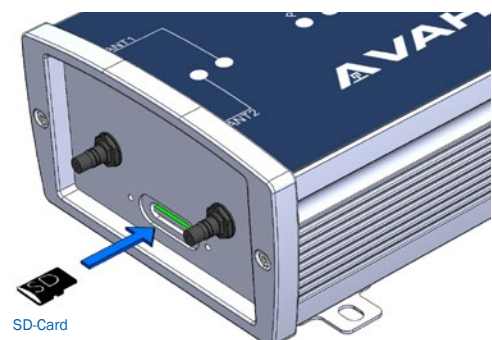

SMGM – SWITCH CONCEPT / SMGM-TC

SWITCH CONCEPT

For interruption-free communication, a stationary source interface's HF signal is split at feed switches to both turnout segments via HF splitters.

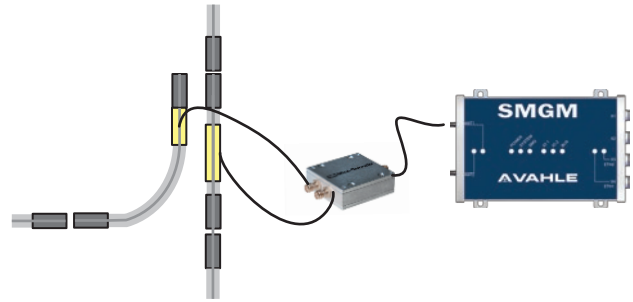

SMGX – SYSTEM OVERVIEW

- 1 SMGM Stationary Segment Interface
- 2 SMGM Mobile Segment Interface
- 3 SMGM HF Cable
- 4 SMGX Profile
- 5 SMGX Mobile Coupler

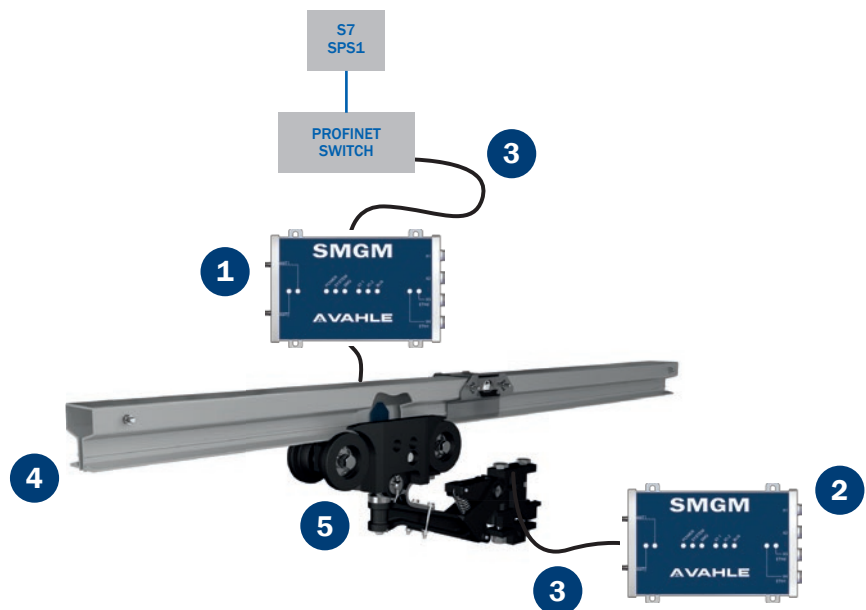

SMGM | SMGX – STATIONARY AND MOBILE INTERFACES

TECHNICAL DATA

ELECTRICAL DATA

Supply voltage	24 VDC ($\pm 10\%$)
Power consumption	Max. 500 mA
Power input.....	<12 W
Start-up time	<4 s

ETHERNET INTERFACE

Data transmission.....	10 BASE-T, 100 BASE-TX
Data rate.....	100 Mbit/s (gross)
Switch functionality.....	Dual-Port Switch
Max. cable length.....	100 m (depending on the cable type)

CONNECTIONS

Power supply	1 x M12, 8-pole, A-coded (for BCC/SMGM-PN with system CAN-Bus)
Ethernet ports	2 x M12, 4-pole, D-coded
RS485 connection	1 x M12, 4-pole, A-coded
HF connections	2 x QLS
SD-Card.....	SD-Card slot

AMBIENT CONDITIONS

Operating temperature	0 °C ... 50 °C
Storage temperature.....	-15 ° ... 60 °C

MECHANICAL DATA

Protection type	IP54
Vibration resistance	3M4 (EN60721-3-3)
Dimensions.....	183 x 118.3 x 63.4 mm
Weight.....	850 g

OPERATING CONDITIONS

Field of application.....	Indoor (SMGM), indoor and outdoor (SMGX)
Speed.....	Max. 180 m/min (SMGM), max. 130 m/min (SMGX)
Curves	Only available for SMGM (radius horizontal min. 750 mm, vertical min. 2300 mm)

DIMENSIONS

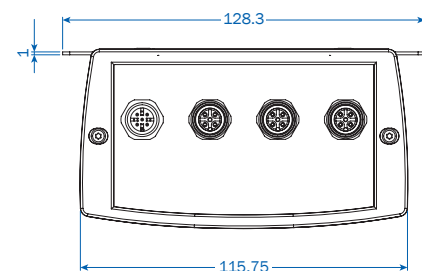
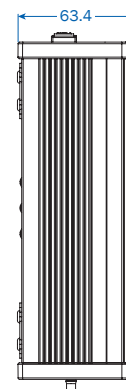
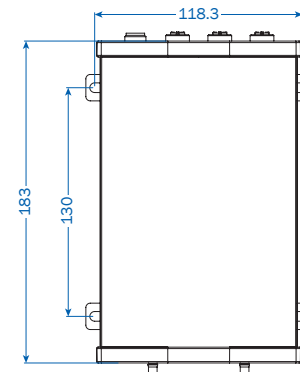

INFORMATION FOR USING INTERFACES

Only components of the same system can be used with each other. I.e. if the interface on the stationary side has „standard configuration,“ the interface on the mobile side must also have „standard configuration.“

The stationary interface SMGM-SI-2 can only be used in conjunction with the BCC/SMGM-PN and a VAHLE DCS control. The SMGM-RU is a universal spare unit. It is the only interface that can adopt the configuration of any other interface.

SMGM | SMGX – STATIONARY AND MOBILE INTERFACES

SYSTEM TYPES



LITE-Interface



Standard / Advanced-Interface

LITE VERSION

The LITE version is applied in applications with one segment and up to four mobile users.

Application: Intralogistics

STANDARD VERSION

The Standard version is applied in applications with min. one segment and up to 15 mobile users.

Applications: Intralogistics, EMS and Skillet

ADVANCED VERSION

The Advanced version is applied in applications with one segment and up to three mobile users.

Applications: Intralogistics and EMS

System	Lite		Standard		Advanced		Cross-System	
Stationary Interfaces								
Description	SMGM-SI-1-LITE		SMGM-SI-1	SMGM-SI-2	SMGM-SI-1-ADV		SMGM-SC	SMGM-RU
No. of segments	1		1	2	1		1	*
Users per segment	4		15	15	3		1	*
Communication cycle	16 ms		16 ms	16 ms	8 / 16 ms		16 ms	*
Process data transmission	Yes		Yes	Yes	Yes (prioritized)		Yes	Yes
Video data transmission	No		No	No	Yes		No	Yes*
Mobile Interfaces								
Description	SMGM-DI-ST1-LITE	SMGM-DI-ST2-LITE	SMGM-DI-ST2	BCC/SMGM-PN	SMGM-DI-ST2-ADV	SMGM-DI-ST1-ADV	-	SMGM-RU
Transfer rate (gross)	100 Mbit/s	100 Mbit/s	100 Mbit/s	100 Mbit/s	100 Mbit/s	100 Mbit/s	100 Mbit/s	100 Mbit/s
No. of mobile coupler	1	2	2	2	2	1	-	*
Process data transmission	Yes	Yes	Yes	Yes	Yes	Yes	-	Yes*
Video data transmission	No	No	No	No	Yes	Yes	-	Yes*
Max. Segment Length								
Type	SMGX	SMGM	SMGM	SMGM	SMGM	SMGX	SMGM	*
Feed method L/2	200 m**	180 m**	120 m**	120 m**	140 m**	500 m**	-	*
No. of mobile users	4	4	15	15	3	3	-	*
No. of mobile couplers	1	2	2	2	2	1	-	*

* The properties of the SMGM-RU (Replacement Unit) depend on the configuration.

** Segment length depends on the number of mobile couplers and the used HF cables

SMGM | SMGX – STATIONARY INTERFACES

RANGE OF PRODUCTS

Description		System	Order No.
SMGM-SI-1-LITE	Segment Interface for one segment and max. four users	LITE	10014867
SMGM-SI-1	Segment Interface for one segment and max. 15 users	Standard	10011066
SMGM-SI-2	Segment Interface for two segments and max. 15 users	Standard	10011064
SMGM-SI-1-ADV	Segment Interface for one segment with ADV Configuration	Advanced	10016752
SMGM-SC	System Controller	Cross-System	10011071
SMGM-RU	Replacement Unit	*	10015129

SMGM | SMGX – MOBILE INTERFACES

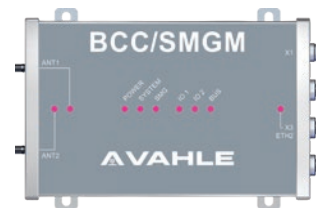

BCC-Interface

RANGE OF PRODUCTS

Description		System	Order No.
SMGM-DI-ST1-LITE	Device Interface LITE for one mobile coupler	LITE	10014897
SMGM-DI-ST2-LITE	Device Interface LITE for two mobile couplers	LITE	10014866
SMGM-DI-ST2	Device Interface Standard for two mobile couplers	Standard	10011069
BCC/SMGM-PN	Communication Interface Profinet Bus Center Control	Standard	10011679
SMGM-DI-ST1-ADV	Device Interface Advanced for one mobile coupler	Advanced	10016753
SMGM-DI-ST2-ADV	Device Interface Advanced for two mobile couplers	Advanced	10016755
SMGM-RU	Replacement Unit	*	10015129

* The properties of the SMGM-RU (Replacement Unit) depend on the configuration.

SMGM | SMGX CABLES



Cable Ecoflex



Cable RG316D

RANGE OF PRODUCTS: <5 M LENGTH

Description	Length	Order No.
Connection cables Plug 0° to 0°		
SMGM-VL-500-QLS-QLS-RG316D	500 mm	10011177
SMGM-VL-1000-QLS-QLS-RG316D	1000 mm	10012478
SMGM-VL-1500-QLS-QLS-RG316D	1500 mm	10012771
SMGM-VL-2000-QLS-QLS-RG316D	2000 mm	10012320
SMGM-VL-3000-QLS-QLS-RG316D	3000 mm	10012477
Connection cables Plug 90° to 0°		
SMGM-VL-500-QLS90-QLS-RG316D	500 mm	10009405
SMGM-VL-1000-QLS90-QLS-RG316D	1000 mm	10009406
SMGM-VL-1500-QLS90-QLS-RG316D	1500 mm	10011834
SMGM-VL-2000-QLS90-QLS-RG316D	2000 mm	10009407
SMGM-VL-2500-QLS90-QLS-RG316D	2500 mm	10014682
SMGM-VL-3000-QLS90-QLS-RG316D	3000 mm	10009408
SMGM-VL-4500-QLS90-QLS-RG316D	4500 mm	10022375
SMGM-VL-5000-QLS90-QLS-RG316D	5000 mm	10009409

RANGE OF PRODUCTS: BCC/SMGM TO DCS CONTROL SYSTEM

Description	Length	Order No.
Cable DCS/BCC – 0.5 m	500 mm	10012475
Cable DCS/BCC – 1.0 m	1000 mm	10012307
Cable DCS/BCC – 1.5 m	1500 mm	10012476
Cable DCS/BCC – 2.0 m	2000 mm	10012308
Cable DCS/BCC – 2.5 m	2500 mm	10012213
Cable DCS/BCC – 3.0 m	3000 mm	10012479

SMGM | SMGX CABLE

RANGE OF PRODUCTS: >5 M LENGTH

Description	Length	Order No.
Extension cables Plug N-socket to N-socket		
SMG-VL-1000-NB-NB-ECOFLEX15	1000 mm	10011174
SMG-VL-1500-NB-NB-ECOFLEX15	1500 mm	10014681
SMG-VL-2000-NB-NB-ECOFLEX15	2000 mm	10011175
SMG-VL-2500-NB-NB-ECOFLEX15	2500 mm	10011510
SMG-VL-3000-NB-NB-ECOFLEX15	3000 mm	10011512
SMG-VL-4000-NB-NB-ECOFLEX15	4000 mm	10011511
SMG-VL-5000-NB-NB-ECOFLEX15	5000 mm	10012879
SMG-VL-5500-NB-NB-ECOFLEX15	5500 mm	10022036
SMG-VL-7000-NB-NB-ECOFLEX15	7000 mm	10011838
Extension cables Plug 90° to N-socket		
SMGM-VL-500-QLS90-N-RG316D	500 mm	10011171
SMGM-VL-750-QLS90-N-RG316D	750 mm	10011567
SMGM-VL-1000-QLS90-N-RG316D	1000 mm	10008185
SMGM-VL-1500-QLS90-N-RG316D	1500 mm	10011192
SMGM-VL-2000-QLS90-N-RG316D	2000 mm	10011172
SMGM-VL-2500-QLS90-N-RG316D	2500 mm	10011509
SMGM-VL-3000-QLS90-N-RG316D	3000 mm	10011173
Extension cables Plug 0° to N-socket		
SMGM-VL-500-QLS-N-RG316D	500 mm	10011176
SMGM-VL-750-QLS-N-RG316D	750 mm	10011568
SMGM-VL-1000-QLS-N-RG316D	1000 mm	10012839
SMGM-VL-1500-QLS-N-RG316D	1500 mm	10014148

SMGM | SMGX – PROFILE



SMGM-Profile

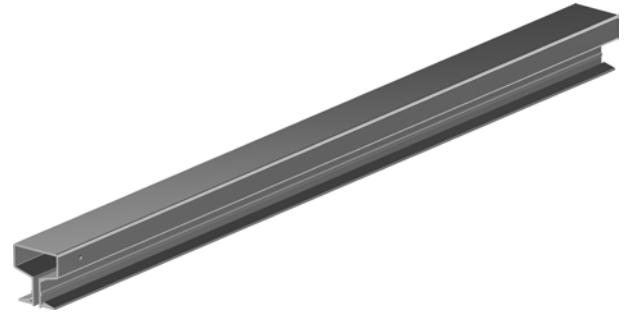

SMGX-Profile

RANGE OF PRODUCTS

Description	Order No.
SMGM-Profile incl. accessories	P9999996*
SMGX-Profile incl. accessories	P9999996*

SMGM | SMGX – PROFILE SUPPORT



SMGM-Solo-Hanger

SMGX-Hanger
incl. halben mounting rail

RANGE OF PRODUCTS

Description	Max. support distance	Order No.
SMGM-Solo-Hanger	1.5 m	10010543
SMGX-Hanger	2.0 m	10016900

* It is a matter of a pseudo order number. Our Techsales will check the profile components in detail by ordering.

SMGM | SMGX – FUNNEL



SMGM-Funnel

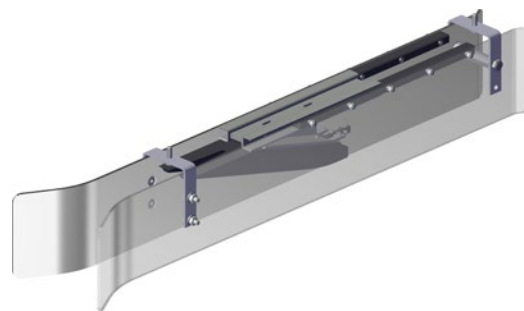

SMGX-Funnel

RANGE OF PRODUCTS

Description	Order No.
SMGM-Solo-Funnel	10016778
SMGX-Funnel	10017003

SMGM | SMGX – MOBILE COUPLER



SMGM-Coupler



SMGX-Coupler

RANGE OF PRODUCTS

Description	Tolerances	Order No.
SMGM-ANTFE-SAMK	±15 mm	10019562
SMGM-ANTFE-SAML	±20 mm	10024386
SMGM Support for mobile coupler	-	10011961
SMGX-SA-UT-011-PH-R	±45 mm ↓ ±60 mm ↗	10012179

SMGM – TRACK CHANGE

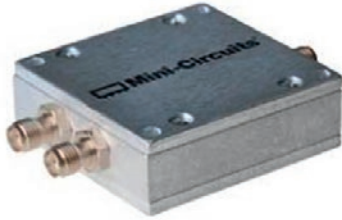

RANGE OF PRODUCTS

Description	Order No.
SMGM-Track Change (HF-Splitter)	10014524

SMGM – SYSTEM INTEGRATION

EXAMPLE: EMS APPLICATION*

- 1 In this application, the SMGM profile is mounted between the APOS optic Datamatrix Code Strip and U10 profile as part of the EMS profile.
- 2 The SMGM mobile coupler is integrated between the APOS Optic reading head and the U10 current collector.
- 3 A special bracket provides a common mounting plate for the APOS Optic reading head, the U10 current collector and also for the SMGM mobile coupler.

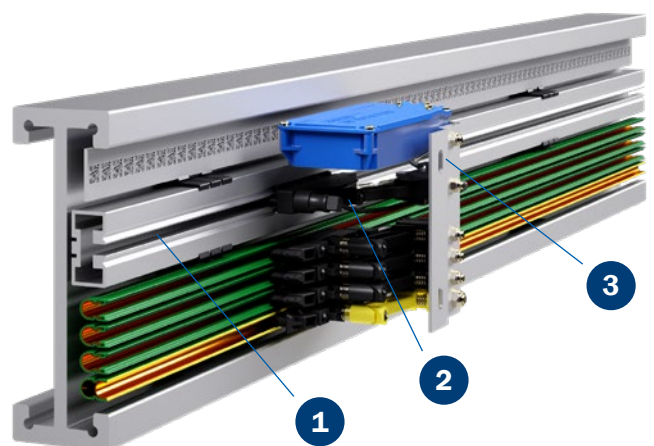

* More system combinations are available on request, please contact our Techsales in case of need. Please take into account that the EMS components are not part of VAHLE delivery scope.



Paul Vahle GmbH & Co. KG

Westicker Str. 52
59174 Kamen
Germany

Phone: +49 2307 704-0

Fax: +49 2307 704-444

info@vahle.de

www.vahle.com